

Twin Head Emergency Light SEM

CATALOG NUMBER	TYPE

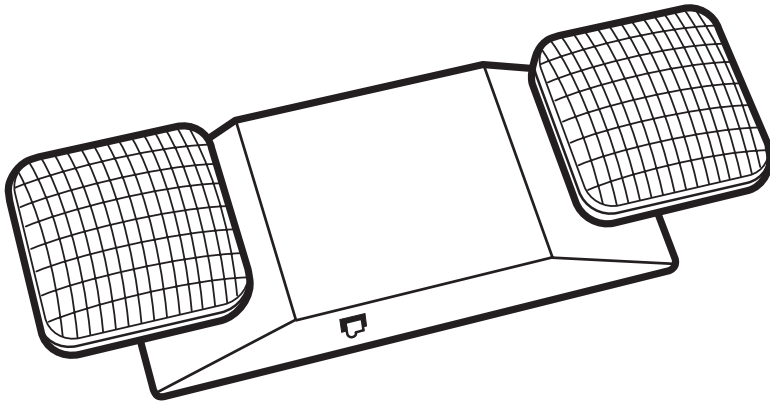

180° coverage from two fully adjustable lighting heads for maximum illumination anywhere you need it

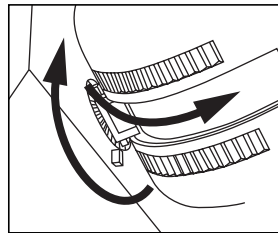

Housing: Injection-molded, V-O flame retardant, high-impact, thermoplastic housing. Compact, low profile design in a white or black finish.

Illumination: Two fully adjustable 5.4 watt, glare-free lighting heads. High performance smooth thermoplastic reflector and polycarbonate lens for optimal light distribution and resistance to discoloration from natural or artificial light sources.

Options: 3 foot 3-wire cord and plug available (option C). Remote capable unit available (option REM). REM option allows for operation of up to two additional 5.4 watt lighting heads. Consult factory for availability of remote heads.

Battery: 6V, sealed lead acid, maintenance-free, rechargeable.

Charging Circuitry: Internal solid-state transfer switch automatically connects the internal battery to the two lamp heads, illuminating them for a minimum of 90-minute emergency operation. Recharging the battery is initiated by a fully automatic solid-state, two-rate charger, which includes current limiting and temperature compensation to assure that optimum recharging rate, for even a fully discharged battery, will be accomplished in 12 hours.

Electrical: Universal transformer for 120 or 277V. Charge rate/power on LED indicator light. Periodic testing for three minutes, every thirty days is recommended to comply with fire codes. LVD (low voltage disconnect) feature activates to prevent battery from deep discharge, but not before the minimum 90-minute emergency operation. UL, C-UL (tested to C860), and ETL Damp location listed. Meets UL924, NFPA 101 Life Safety Code, and NEC requirements.

Mounting: Surface mount. Easy connect back plate snaps into place making the electrical connection. Back plate fits most standard junction boxes. Hardware included.

Critical Applications: Simkar strives to offer the most current product designs and value. Consequently, all Simkar products are subject to redesign and revision. Critical applications such as size, operating temperature, or sensor operation should be confirmed with the factory.

Warranty: Five year warranty on all electronics and housing. Batteries are pro-rated warranted for 5 years.

FEATURES AND BENEFITS

Easy connect back plate	➤	Simple installation with hands free wiring
Light heads swivel 180°	➤	Maximum illumination where you need it
Thermoplastic housing	➤	Resists discoloration from natural or artificial light, maintains new look
Damp Location listed	➤	Durable and long lasting performance
6V Battery	➤	Maintenance-free, rechargeable, heavy duty
Push to test switch	➤	Complies with fire codes
Dual voltage 120/277V	➤	No mixups and less inventory to carry

ORDERING INFORMATION

Example: SEMBC

SEM

SERIES

SEM - SIMKAR Emergency Light

HOUSING

B - Black
W - White

OPTION

C - Cord & Plug
REM - Remote capable

Twin Head Emergency Light

PHOTOMETRIC DATA

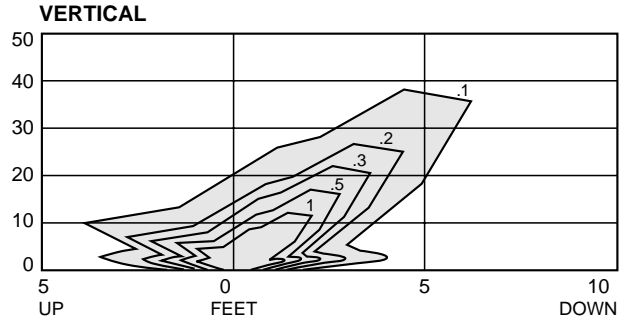
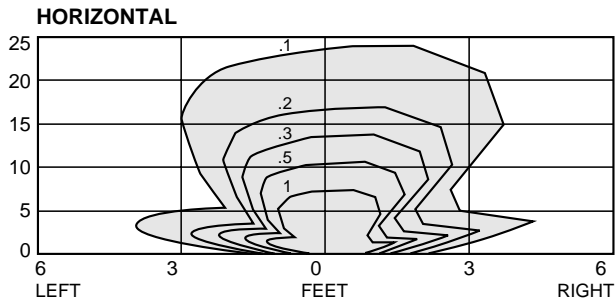

DRAWINGS AND DIMENSIONS

